

# Dry Erase Flip Top Student Table

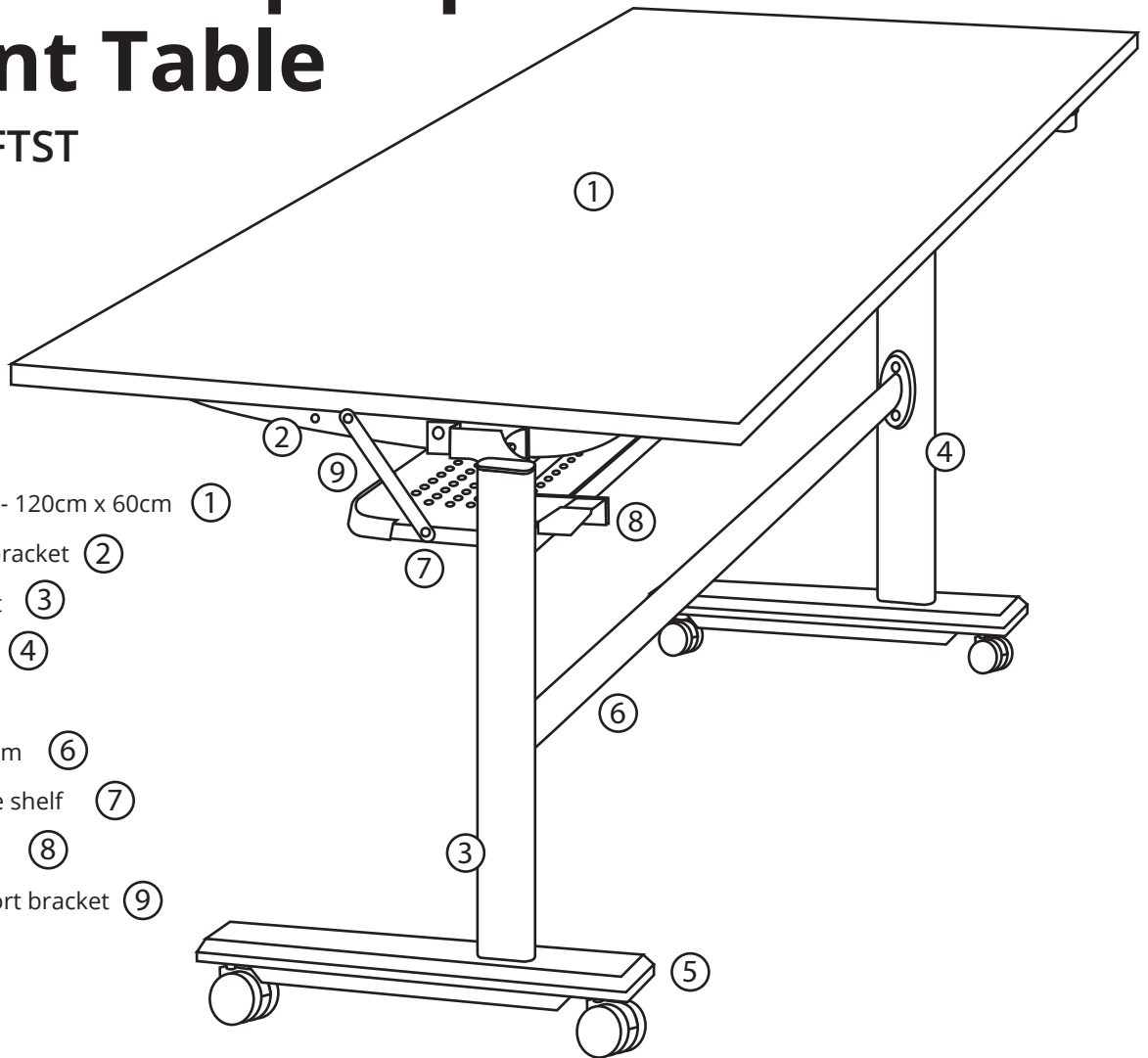







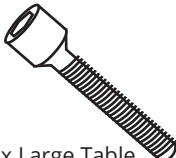

Code: ERDEFTST

## Contents:

- 1 x Dry Erase table top - 120cm x 60cm ①
- 1 x Table top support bracket ②
- 1 x Vertical stand - Right ③
- 1 x Vertical stand - Left ④
- 2 x Base feet ⑤
- 1 x Middle support beam ⑥
- 1 x Under table storage shelf ⑦
- 1 x Flip top lever beam ⑧
- 1 x Storage shelf support bracket ⑨

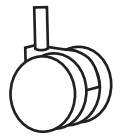

## Hardware:

 2 x Large Table top support bolts	 4 x Support beam bolts	 4 x Base feet bolts	 4 x Shelf support bracket bolts	 4 x Shelf support bracket hex nuts	 2 x Large Table top support hex nuts
 4 x Small washers	 2 x Large washers	 8 x Dry Erase Table Top screws	 2 x Vertical stand caps	 2 x Flip top lever covers	 4 x Casters

**Elizabeth Richards School Supplies PTY LTD**

**Ph: 1300 137 064**

**E: sales@elizabethrichards.com.au**

**www.elizabethrichards.com.au**

## The Basics

You will need:

- 1 x Small Spanner (provided)
- 1 x Small Allen Key (provided)
- 1 x Large Allen Key (provided)

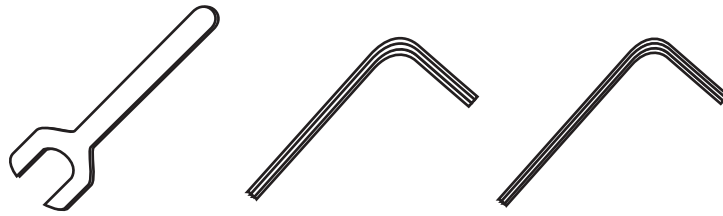

**To start: Unpack contents and lay out on the floor. Identify all the parts and read through instructions to familiarize yourself with the construction process.**

### Step 1

Secure each vertical stand (3) & (4) to each base foot (5) using the 4 base feet bolts.

Tighten using the Allen Key provided.

Attach the middle support beam (6) between the two vertical stands using the 4 support beam bolts..

**Tip: Dont tighten this part yet as the Shelf and the Support Bracket still need to slip in between the vertical posts.**

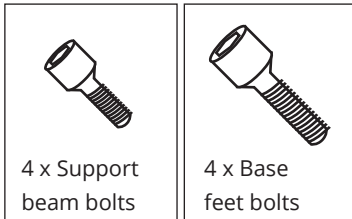

### Step 2

While the stand is still loose, fit the Under Table Storage Shelf (7) and the Shelf support bracket (9) into their correct holes on the vertical stands (3) & (4).

**Note:**

**There are springs that fit between the Vertical Stand (3) and the Support bracket (9). ( See diagram for correct orientation )**

**Now tighten the support beam bolts, securing the entire unit.**

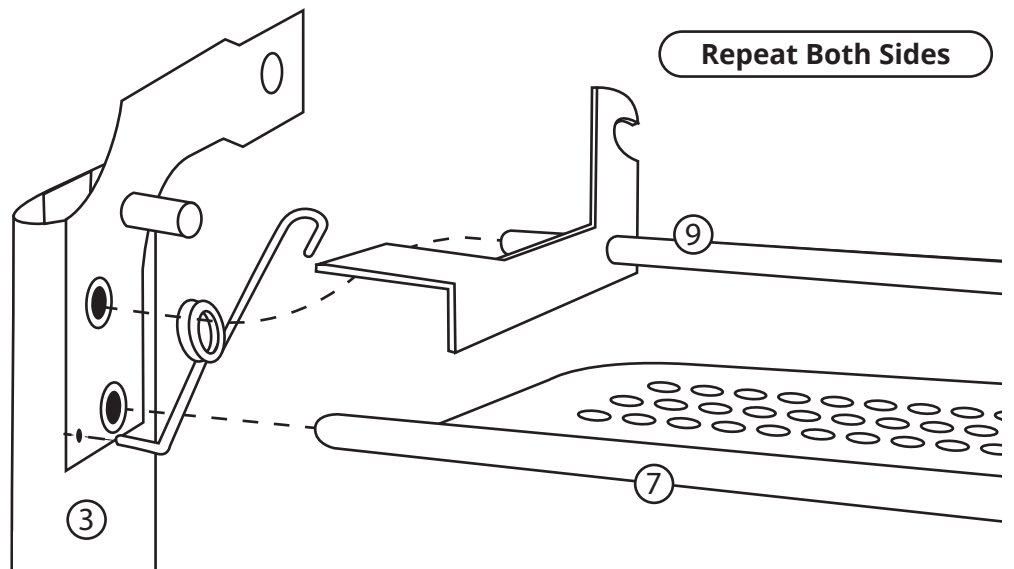
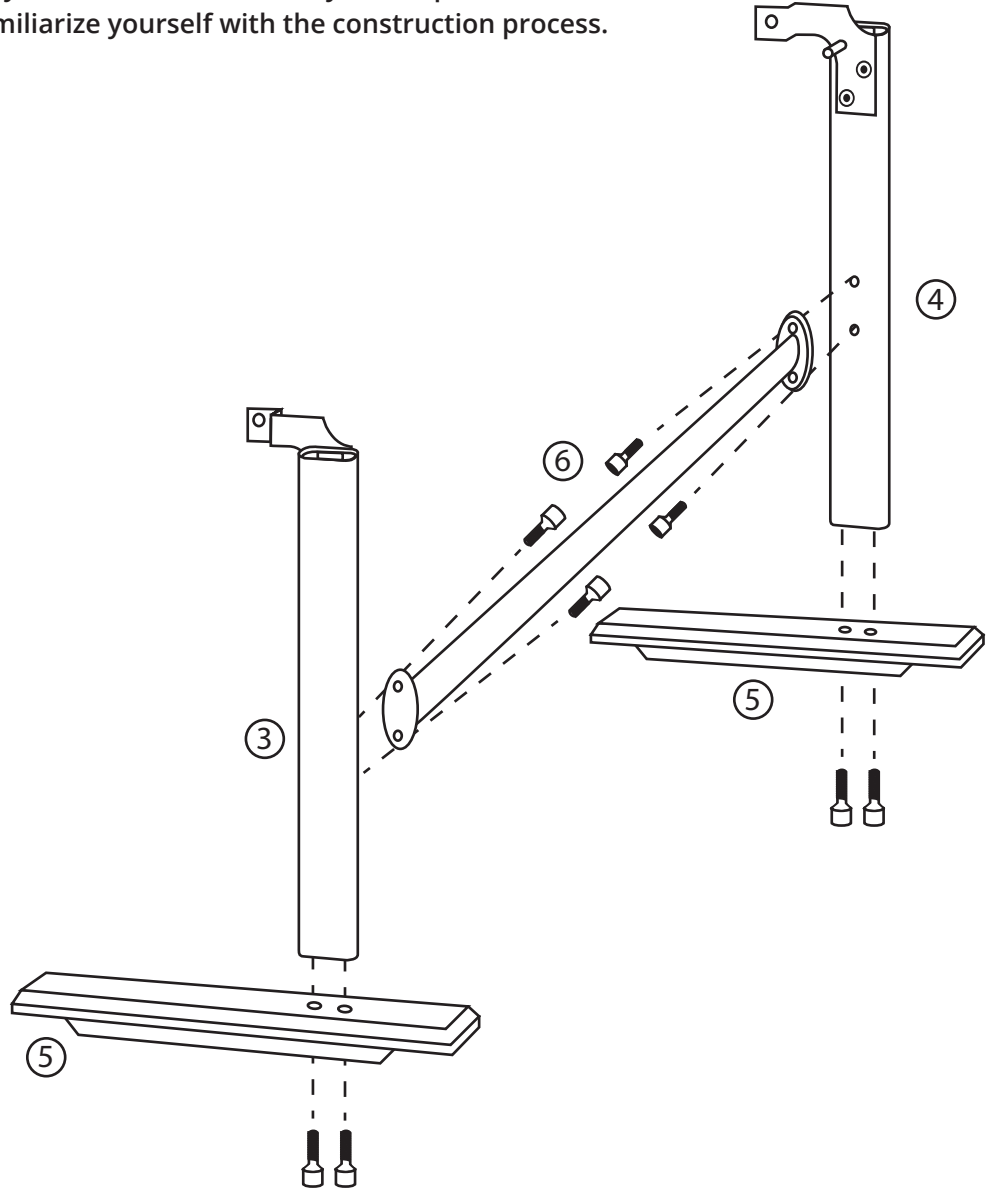

# Step 3

Screw in the four Casters into the base feet using the supplied Spanner.

Using the two large table top support bolts and washers, place the table top support bracket (2) into the main frame and secure with the 2 support bolts. See the red markers for placement.

Gently tap the vertical stand caps into the tops of the vertical stand.

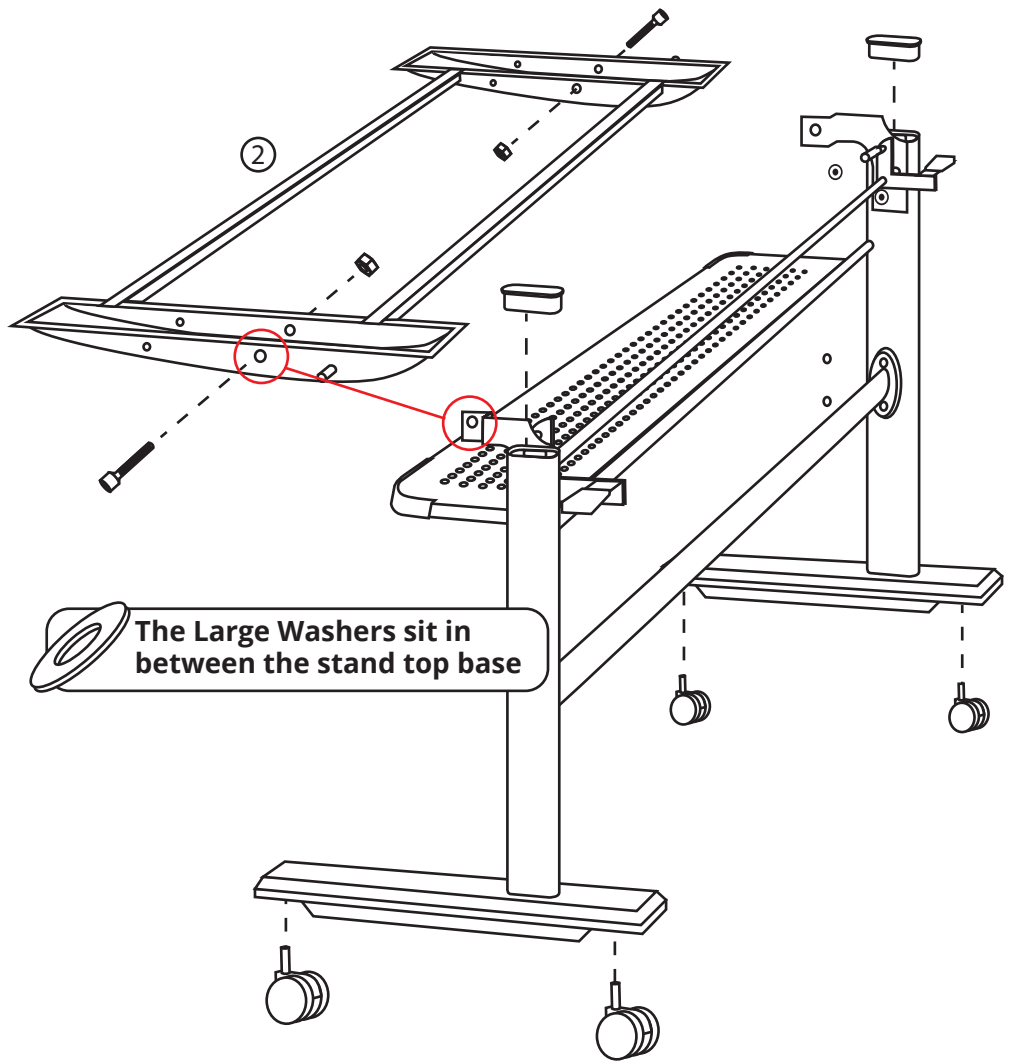
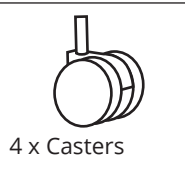
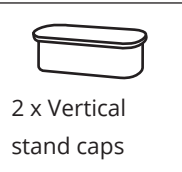

# Step 4

The spring that is now set between the vertical stand (3) and the Shelf support bracket (7) needs to be pulled back to rest around the 'latch' section of the bracket. See image of position A to position B.

This can be done using a pair of pliers. Clasp the hook and pull it back gently into place.

OR

A length of string can be looped around the hook and pulled into place also.

OR

A length of string can be looped around the hook and pulled into place also.

**Repeat this for both springs.**

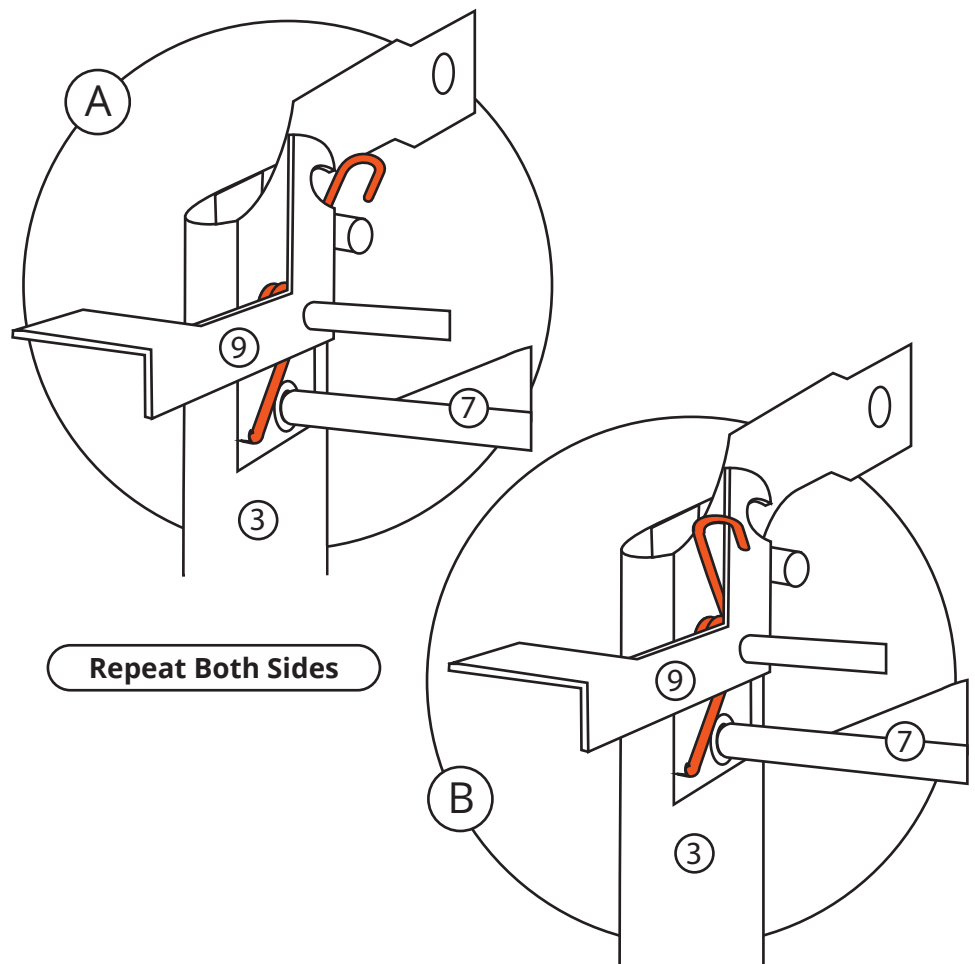

## Step 5

Attach the 2 shelf support brackets ⑨ to either side of the stand using the 4 Shelf support bracket bolts and nuts.

The two lever covers easily push onto the Shelf support bracket tabs.



4 x Shelf support bracket bolts



4 x Shelf support bracket hex nuts



2 x Flip top lever covers



8 x Dry Erase Table Top screws

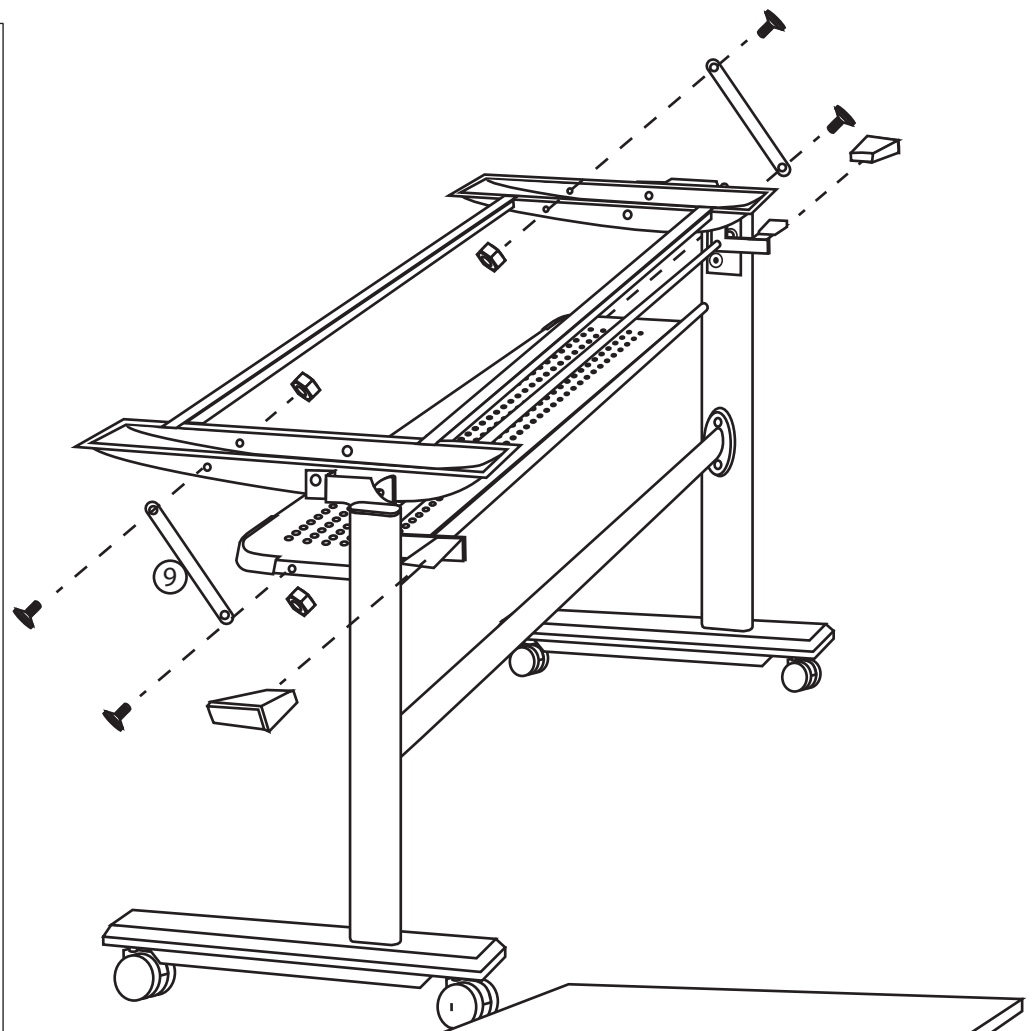

## Step 6

Place the Dry erase top ① on the support bracket and secure to the main frame using the 8 screws.



8 x Dry Erase Table Top screws

**To flip the dry erase Table Top up to become an instant mobile whiteboard - just depress the levers to release the top and lift it to a vertical position.**

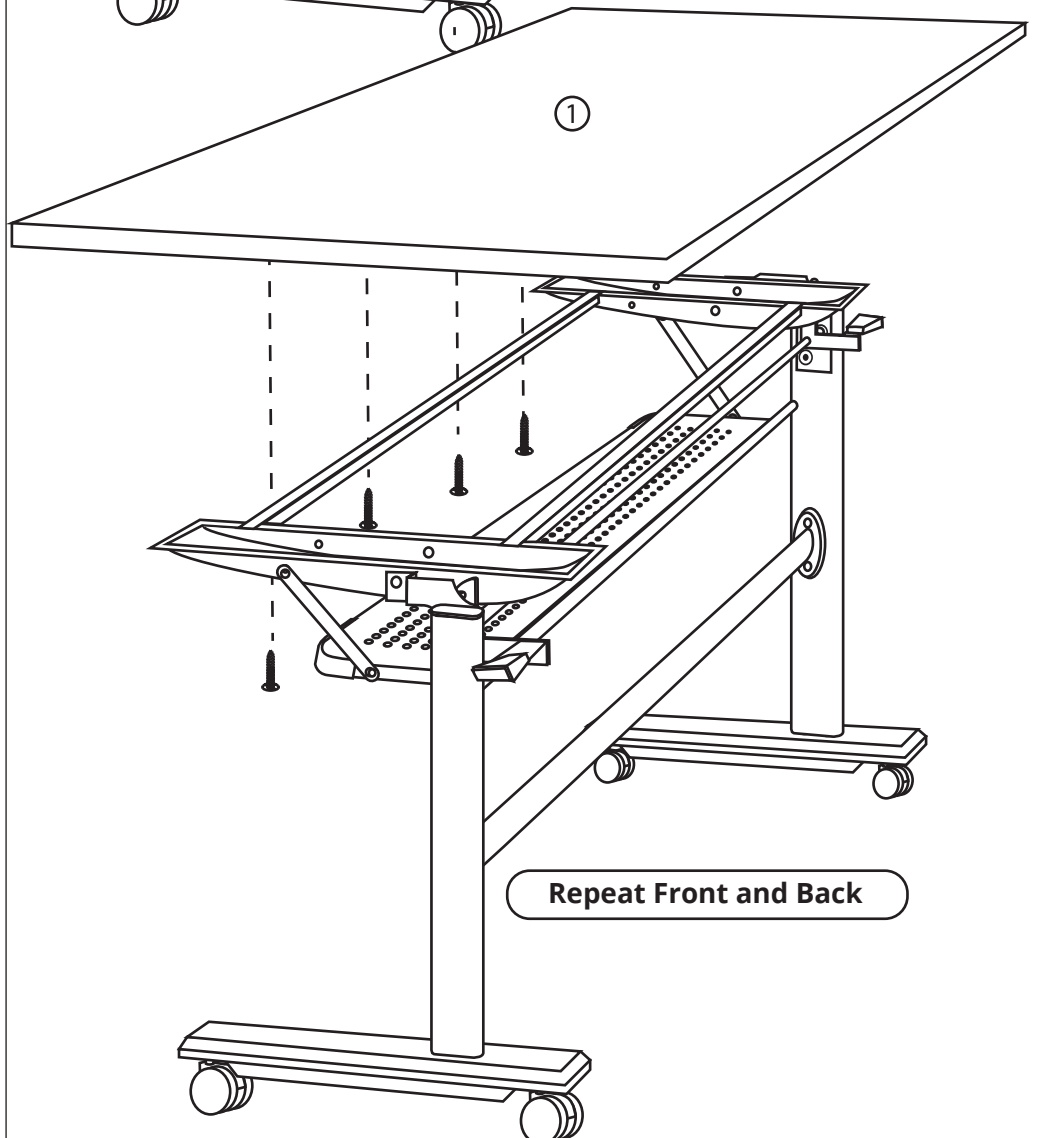

Repeat Front and Back